

E. B. ALLEN.

MACHINE FOR SEWING LONG LENGTHS OF FABRIC.

No. 548,736.

Patented Oct. 29, 1895.

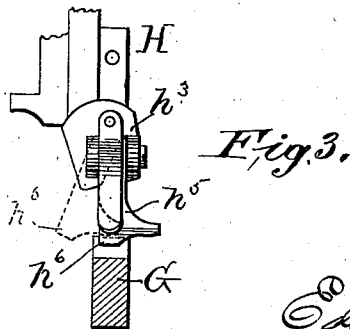
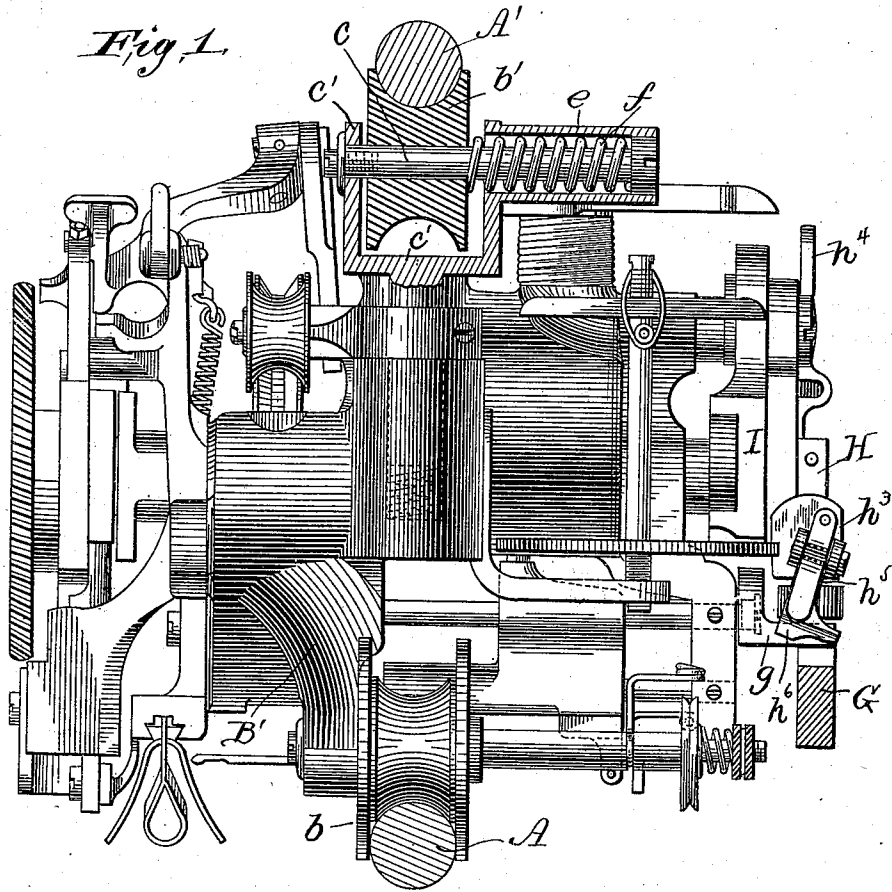

WITNESSES:
C. W. Benjamin
C. M. Sweeney

INVENTOR,
Edward B. Allen
 BY *Henry Falver*
 ATTORNEY.

E. B. ALLEN.

MACHINE FOR SEWING LONG LENGTHS OF FABRIC.

No. 548,736.

Patented Oct. 29, 1895.

Fig. 2.

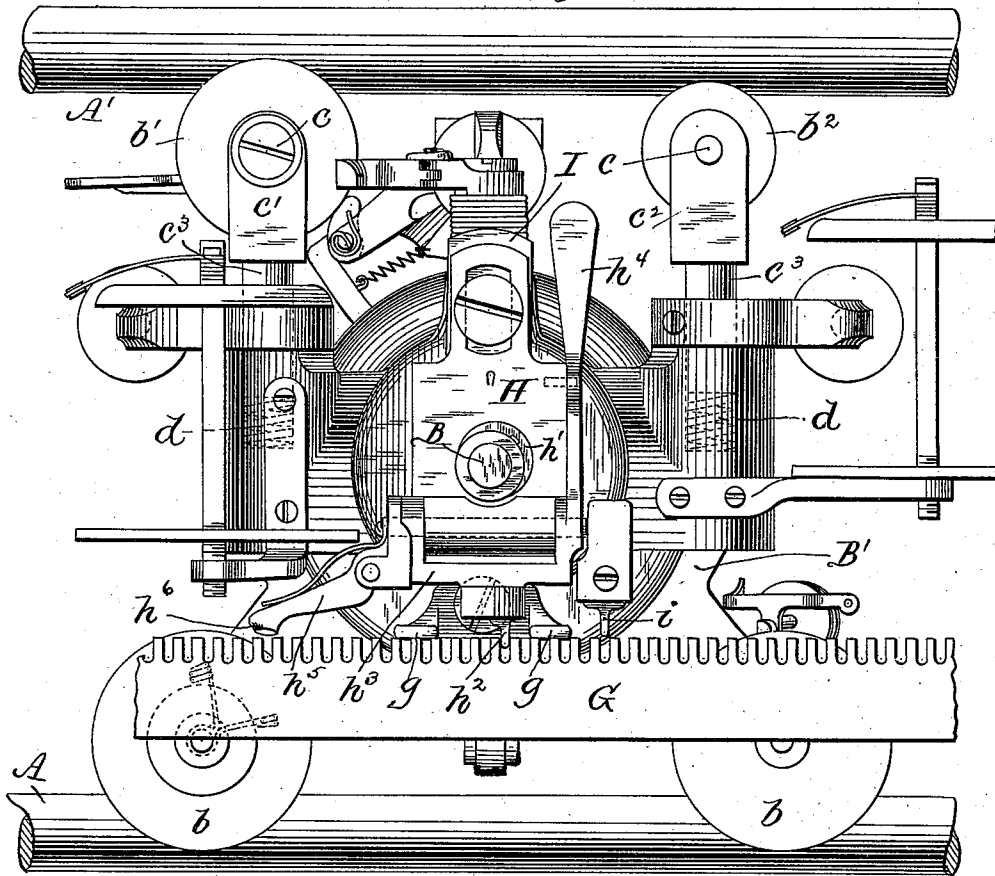

Fig. 4.

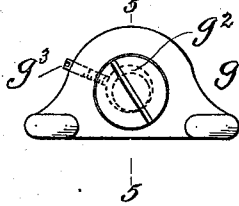
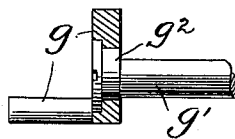

Fig. 5.



WITNESSES:

C. W. Benjamin
C. M. Sweeney

INVENTOR:

Edward B. Allen
 BY *Henry Salter*
 ATTORNEY.

UNITED STATES PATENT OFFICE.

EDWARD B. ALLEN, OF ELIZABETH, NEW JERSEY, ASSIGNOR TO THE SINGER MANUFACTURING COMPANY, OF NEW JERSEY.

MACHINE FOR SEWING LONG LENGTHS OF FABRIC.

SPECIFICATION forming part of Letters Patent No. 548,736, dated October 29, 1895.

Application filed June 26, 1895. Serial No. 554,105. (No model.)

To all whom it may concern:

Be it known that I, EDWARD B. ALLEN, a citizen of the United States, residing at Elizabeth, in the county of Union and State of New Jersey, have invented certain new and useful Improvements in Traveling Sewing-Machines, of which the following is a specification, reference being had therein to the accompanying drawings.

This invention relates to certain improvements in the traveling carpet-sewing machine shown and described in my Patent No. 524,966, granted August 28, 1894, and has for its principal object to provide means whereby the traveling machine may be yieldingly held and guided so that it may adapt itself to any relative irregularities which there may be between the guideway or tracks on which the machine runs and the rack-bar engaged by the tooth of the feeding-lever which propels the machine along, it being found in practice that it is practically impossible to put up long sections of these tracks and rack-bars in such a manner that the tracks and rack-bars will always be exactly parallel or so that the rack-bars will always be of exactly the same height relative to the tracks or guideway.

Another object of my invention is to provide a stopping-pawl, which is so connected with the feeding-lever that when the tooth of the latter is thrown laterally out of engagement with the teeth of the rack-bar, to permit the machine to be run backward, said pawl will be moved into such position as to engage the rack-bar and thus prevent the machine from running away forward should there be friction enough between the driving and belt-guide pulleys and the endless driving-belt to draw the machine along on its tracks or rails.

In the drawings, Figure 1 is a front end view of my improved machine in connection with the tracks and rack-bar, and Fig. 2 is a side view of the same. Fig. 3 is a detail view of the rack-bar and safety catch or pawl, and Figs. 4 and 5 are detail views of the stop which bears on the rack-bar.

The lower and upper tracks or rails A and A' are preferably in the form of round bars, fitted to which are lower grooved wheels *b*

and upper grooved wheels *b'* and *b''*, suitably mounted relative to the frame B' of the machine. The lower wheels *b* are preferably mounted in fixed spindles and in such a manner that they can have no appreciable lateral movements thereon. The upper wheels *b'* and *b''* run on axles or pins *c*, mounted in forks *c'* and *c''*, having shanks *c'''*, received in sockets formed for their reception in the machine-frame, and in which sockets, beneath said shanks, are placed coil-springs *d*, which force said upper grooved wheels upward into yielding contact with the upper track or rail A', and also hold the lower grooved wheels downward on the lower track or rail A.

The forks *c'* and *c''*, receiving the wheels *b'* and *b''*, are somewhat wider between their arms than the said wheels, so that the latter can have limited sidewise movements on their pins or axles to permit the machine to move laterally slightly at its top. The fork *c'* has a hollow extension or sleeve *e*, which receives a coil-spring *f*, which, pressing against the wheel *b'*, held steady laterally by the fixed track or rail A', has a tendency to tilt the top of the machine over toward the right, Fig. 1, this tendency being resisted by a stop *g*, attached to the machine-frame and resting on the rack-bar G, said stop *g* being preferably pivoted and having two separated parts or arms bearing on said rack-bar and being thus the better adapted to accommodate itself to any irregularities of the rack-bar or any variations of the relative positions of the rack-bar and tracks.

To provide for adjustment to compensate for wear, the pin or rod *g'* on which the stop *g* is pivoted is provided with an eccentric portion *g''*, received in a round hole in the shank of said stop, so that by turning said rod more or less the said stop may be raised or lowered slightly to bring it into proper position relative to the rack-bar, said rod being fixed in position after adjustment by any suitable means, as by a set-screw *g'''*.

The feeding mechanism of my improved machine is essentially the same as in my patent hereinbefore referred to in that it consists of a swinging and vertically reciprocating feed-lever H, operated by an eccentric *h'* on the driving-shaft B of the machine, and

which feed-lever is provided with a feeding-tooth h^2 to engage the teeth of the rack-bar G, said tooth h^2 being carried by a pivoted yoke h^3 , having a handle h^4 , by means of which
 5 said tooth may be thrown out sidewise to disengage it from the rack when it is desired to run the machine freely forward and backward, the holding-bar I, which reciprocates vertically only, being at such times lifted, so
 10 that its holding-tooth i is clear of the rack-bar. It has, however, been found that with the feeding and holding teeth both disengaged from the rack-bar G the friction of the driving-belt running in contact with the driving
 15 and guide pulleys of the machine is sometimes sufficient to start the machine forward on its tracks and cause the machine to run away and be injured. To obviate this difficulty, I have provided the yoke h^3 with a
 20 spring-pressed safety catch or pawl h^5 , having a tooth h^6 so arranged that when said yoke is moved by said handle to disengage the feeding-tooth h^2 from the teeth of the rack-bar G the said tooth h^6 will be engaged with said
 25 rack-bar and will thus prevent any accidental forward movement of the machine, and when the feeding-tooth h^2 is in engagement with the teeth of the said rack-bar said holding-tooth h^6 will be disengaged therefrom.
 30 The spring-pressed safety catch or pawl h^5 permits the machine to be run freely backward when the tooth h^6 is in contact with the rack-bar, said tooth in such movement riding freely over the teeth of the said rack-bar, and
 35 should it be desired at such times to run the machine forward the operator has merely to lift the pawl h^5 with his finger.

Having thus described my invention, I claim and desire to secure by Letters Patent—

1. The combination with a guideway or tracks and a traveling sewing machine to run thereon and provided with one or more guide wheels mounted for lateral movement relative to the machine frame, of a rack-bar, a feeding mechanism co-operating with said rack-bar, to move the machine forward intermittingly, a spring interposed between one of said wheels and a part of the machine and having a tendency to tilt the machine over toward said rack-bar, and a stop yieldingly forced in contact with said rack-bar by said spring; whereby the machine is permitted to adapt itself to any irregularities or inequalities of the relative positions of the rack-bar and tracks.

2. The combination with the lower and upper rails or tracks A and A' and a traveling sewing machine to run thereon and provided

with the lower guide-wheels b and the upper guide wheels b' and b^3 , the forks c' and c^2 by which the said upper guide-wheels are carried and in which they are journaled, said forks being wider between their arms than said wheels, to permit of relative lateral movements of said wheels and forks, the coil-spring f arranged to press against the said wheel b' and a part of the machine, the rack-bar G, a feeding mechanism co-operating with said rack-bar, to move the machine forward intermittingly, and the stop g arranged to bear on said rack-bar by the pressure of the said spring.

3. The combination with the lower and upper rails or tracks A and A' and a traveling sewing machine to run thereon and provided with the lower guide-wheels b and the upper guide wheels b' and b^3 , the forks c' and c^2 by which the said upper guide-wheels are carried and in which they are journaled, said forks being wider between their arms than said wheels, to permit of relative lateral movements of said wheels and forks, the coil-spring f arranged to press against the said wheel b' and a part of the machine the rack-bar G, a feeding mechanism co-operating with said rack-bar, to move the machine forward intermittingly, and the stop g arranged to bear on said rack-bar by the pressure of the said spring, said stop consisting of two separated parts or arms, and the rod or pin g' on which said stop is pivoted and which is provided with the eccentric portion g^2 received in a hole in the shank of said stop, to provide for vertical adjustment of the latter.

4. The combination with a track or guideway and a traveling sewing machine to run thereon, of a rack-bar parallel with the said track or guideway, a feeding mechanism co-operating with said rack-bar to move the machine intermittingly forward and comprising the vertically reciprocating holding bar I having the tooth i , and the vertically reciprocating and horizontally swinging feed lever H provided with the pivoted part or yoke h^3 having the feeding tooth h^2 , said yoke having attached thereto the spring-pressed safety catch or pawl h^5 having a tooth h^6 arranged to be thrown into engagement with the teeth of said rack-bar when the said feeding tooth h^2 is disengaged therefrom, and vice versa.

In testimony whereof I affix my signature in presence of two witnesses.

EDWARD B. ALLEN.

Witnesses:

HENRY CALVER,
 JOSEPH F. JAQUITH.